

Entangled Photon Generation From a Three-Level Laser with a Parametric Amplifier and Coupled to a Thermal Reservoir



Negasa Belay

Abstract: In this article we study squeezing and statistical properties of light producing by a non-degenerate three-level laser with the parametric amplifier and coupled to a thermal reservoir. With the aid of master equation, we obtain stochastic differential equations. Applying solutions of resulting differential equations, we calculate quadrature variance, the mean and variance of photon number, the photon number correlation. However, the two-mode driving light has no effect on the squeezing properties of the cavity modes. On the other hand, parametric amplifier and thermal reservoir increase the mean and variance of photon number. Furthermore, employing the same solutions, we also obtain anti normally ordered characteristic function defined in the Heisenberg picture. For a linear gain coefficient of ($A = 100$), for a cavity damping constant of $K = 0.8, \mu = 0$ and for thermal reservoir $n_{th} = 0$, the maximum intra cavity photon entanglement is found at steady state and at threshold to be 60%.

Keywords: Master Equation; Solution of Stochastic Differential Equations; Entanglement Amplification and Langvian Equation.

I. INTRODUCTION

Quantum Optics, the union of quantum field theory and physical optics, undergoing a time of revolutionary change. In recent years, the subject of squeezing light has received a great deal of attention by several authors [1-10]. These non-classical states of light (squeezed states) are characterized by a reduction of quantum fluctuations (noise) in one quadrature component of light below the vacuum level, or below that achievable in a coherent state, at the expense of increased fluctuations in the other component such that the product of these fluctuations still obeys the uncertainty relation. Squeezed light has potential applications in low-noise communications and precision measurements [11,12]. A parametric oscillator has been considered as an important source of squeezed light. It is one of the most interesting and well characterized optical devices in quantum optics. In a cascade three-level laser, three level atoms in a cascade configuration are injected into a cavity coupled to a thermal reservoir via a single-port mirror. When a three-level

atom in a cascade configuration makes a transition from the top to the bottom level via the intermediate level, the two photons are generated as shown in figure.1 below. In this device a pump photon interacts with a nonlinear crystal inside a cavity and is down-converted into two highly correlated photons. If these photons have same frequency the device is called a degenerate parametric oscillator, otherwise it is called a non-degenerate parametric oscillator.

The quantum fluctuations and photon statistics of signal mode produced by a non-degenerate parametric oscillator coupled to a two-mode thermal reservoir have been analyzed employing the pertinent Fokker Planck equation or the quantum Langevin equations. The quantum dynamics of a non-degenerate parametric oscillator coupled to a thermal reservoirs have been analyzed employing the Q function obtained by solving the Fokker-Planck equation using the propagator method [13]. When two particles, such as a pair of photons or electrons, become entangled, they remain connected even when separated by vast distances (quantum Entanglement). A two mode sub harmonic generator at the lower and above threshold has been theoretically predicted to be a source of light in an entangled state [14]. Recently, the experimental realization of the entanglement in two-mode sub harmonic generator has been demonstrated by Zhang et al. [15]. On the other hand, Xiong et al. [16] have recently proposed a scheme for an entanglement based on a non-degenerate three-level laser can atoms are injected at the lower level and the top levels are coupled by a strong coherent light. They have found that a non-degenerate three level laser can generate light in an entangled state employing the entanglement criteria for bipartite continuous variables states. Moreover, Tan et al. [17] have extended the work of Xiong et al. and examined the generation and evolution of entangled light in the Wigner representation using the sufficient and necessary in reparability criteria for a two-mode Gaussian state proposed by Duan et al. [18] and Simon [19]. The generation and manipulation of entanglement has attracted a great deal of interest owing to their wide applications in quantum teleportation [20], quantum dense coding [21], quantum computation [22], quantum error correction [23], and quantum cryptography [24]. The variance of the quadrature operators and the photon number distribution for the signal-idler modes Producing by generation of entanglement from non-degenerate three level laser with parametric oscillation have also been studied applying the pertinent Langevin equations [25-27].

Manuscript received on 06 January 2023 | Revised Manuscript received on 13 April 2023 | Manuscript Accepted on 15 April 2023 | Manuscript published on 30 April 2023.

*Correspondence Author

Negasa Belay*, Department of Physics, Jimma University, P. O. Box 378, Jimma, Ethiopia. E-mail: negib120@gmail.com, ORCID ID: <https://orcid.org/0000-0002-9232-3514>

© The Authors. Published by Lattice Science Publication (LSP). This is an open access article under the CC-BY-NC-ND license (<http://creativecommons.org/licenses/by-nc-nd/4.0/>)

Entangled Photon Generation From a Three-Level Laser with a Parametric Amplifier and Coupled to a Thermal Reservoir

On the other hand, obtaining stochastic differential equations, associated with the normally ordering for the cavity mode variables appears to involve a relatively less mathematical task. We first obtain stochastic differential equations for the cavity mode variables by applying the pertinent Master equation. With the aid of resulting equations, we calculate the quadrature variance for the two-mode cavity radiation and the squeezing. In addition, we determine the mean photon number, the photon number entanglement, and the variance of the photon number difference, the intensity difference, and the photon number correlation. We also calculate the mean, the variance, and the photon number correlation, in the absence of the parametric amplifier ($\mu = 0$).

II. MASTER EQUATION

We first drive the equation of evolution of density operator for the three-level laser applying the linear and the adiabatic approximation schemes [4-7]. Then after obtaining the properties of the reservoir sub mode operators, we drive the time evolution of the reduced density operator for the cavity modes coupled to a two-mode thermal reservoir. Finally, with the help of the two resulting equations, we write the master equation for the system under consideration. We represent the top, intermediate, and bottom levels of a three-level atom in a cascade configuration by $|a\rangle$, $|b\rangle$ and $|c\rangle$, respectively, as shown in Figure. 1.

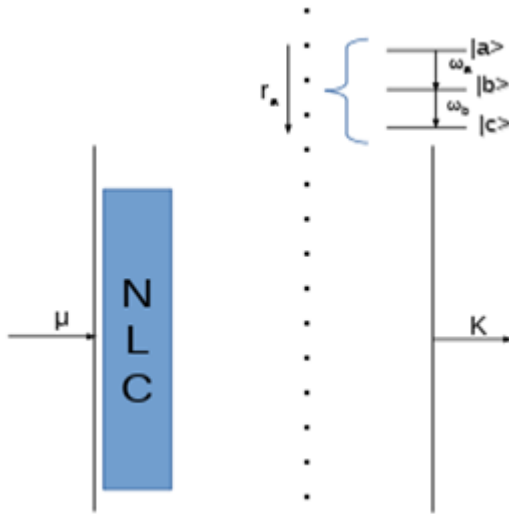

Figure 1. Schematic representation of a non-degenerate three level laser with a parametric amplifier and a thermal reservoir.

This figure shows the Entangled Photon Generation from a Three-Level Laser with a Parametric Amplifier and coupled to a thermal reservoir. In addition, we assume the two modes a and b to be at resonance with the two transitions $|a\rangle$ to $|b\rangle$ and $|b\rangle$ to $|c\rangle$ dipole allowed respectively, and direct transition between level $|a\rangle$ and level $|c\rangle$ to be dipole forbidden.

The interaction of a non-degenerate three-level atom with the cavity modes can be described by the Hamiltonian

$$\hat{H}_1 = ig[|a\rangle\langle b|\hat{a} - \hat{a}^\dagger|b\rangle\langle a| + |b\rangle\langle c|\hat{b} - \hat{b}^\dagger|c\rangle\langle b|], \quad (1)$$

where g is the coupling constant and \hat{a} (\hat{b}) are annihilation operators for the cavity modes. Moreover, the Hamiltonian describing the parametric interaction [8-11],

with the pump mode treated classically, can be written as

$$\hat{H}_2 = i\mu(\hat{a}^\dagger\hat{b}^\dagger - \hat{a}\hat{b}), \quad (2)$$

In which μ is proportional to the amplitude of the pump mode [12-14]. Here, we take the initial state of a single three-level atom and hence, the density operator of a single atom is

$$\hat{\rho}_A(0) = \rho_{aa}^{(0)}|a\rangle\langle a| + \rho_{ac}^{(0)}|a\rangle\langle c| + \rho_{ca}^{(0)}|c\rangle\langle a| + \rho_{cc}^{(0)}|c\rangle\langle c|, \quad (3)$$

Moreover, employing Eq. 1, the master equation for the cavity modes coupled to thermal reservoir, can be put in the form

$$\begin{aligned} \frac{d}{dt}\hat{\rho}(t) = & -i[\hat{H}_S, \hat{\rho}] + g(\rho_{ab}\hat{a}^\dagger - \hat{a}^\dagger\hat{\rho}_{ab} + \rho_{bc}\hat{b}^\dagger \\ & - \hat{b}^\dagger\rho_{bc} + \hat{a}\rho_{ba} - \rho_{ba}\hat{a} + \hat{b}\rho_{cb} - \rho_{cb}\hat{b}) \\ & + \frac{\kappa}{2}(\bar{n}_{th} + 1)(2\hat{a}\hat{\rho}\hat{a}^\dagger - \hat{a}^\dagger\hat{a}\hat{\rho} - \hat{\rho}\hat{a}^\dagger\hat{a}) \\ & + \frac{\kappa}{2}\bar{n}_{th}(2\hat{a}^\dagger\hat{\rho}\hat{a} - \hat{a}\hat{a}^\dagger\hat{\rho} - \hat{\rho}\hat{a}\hat{a}^\dagger) \\ & + \frac{\kappa}{2}(\bar{n}_{th} + 1)(2\hat{b}\hat{\rho}\hat{b}^\dagger - \hat{b}^\dagger\hat{b}\hat{\rho} - \hat{\rho}\hat{b}^\dagger\hat{b}) \\ & + \frac{\kappa}{2}\bar{n}_{th}(2\hat{b}^\dagger\hat{\rho}\hat{b} - \hat{b}\hat{b}^\dagger\hat{\rho} - \hat{\rho}\hat{b}\hat{b}^\dagger), \end{aligned} \quad (4)$$

in which the matrix element $\rho_{\alpha\beta}$ is defined by

$$\rho_{\alpha\beta} = \langle\alpha|\hat{\rho}_{AR}|\beta\rangle, \quad (5)$$

With $\alpha; \beta = a, b, c$. Using once more the adiabatic approximation scheme, we see that

$$\hat{\rho}_{ab} = \frac{gr_a}{\gamma^2}(\rho_{ac}^{(0)}\hat{\rho}\hat{b}^\dagger - \rho_{aa}^{(0)}\hat{\rho}\hat{a}), \quad (6)$$

$$\hat{\rho}_{bc} = \frac{gr_a}{\gamma^2}(\rho_{cc}^{(0)}\hat{\rho}\hat{b}^\dagger - \rho_{ac}^{(0)}\hat{a}^\dagger\hat{\rho}). \quad (7)$$

Finally, on account of Eqs. (6), and (7), the equation of evolution of the density operator for the cavity modes given by Eq. (4), takes the form

$$\begin{aligned} \frac{d}{dt}\hat{\rho}(t) = & -i[\hat{H}_2, \hat{\rho}] + \frac{\kappa}{2}(\bar{n}_{th} + 1)[2\hat{a}\hat{\rho}\hat{a}^\dagger - \hat{a}^\dagger\hat{a}\hat{\rho} - \hat{\rho}\hat{a}^\dagger\hat{a}] \\ & + \frac{1}{2}(A\rho_{aa}^{(0)} + \kappa\bar{n}_{th})[2\hat{a}^\dagger\hat{\rho}\hat{a} - \hat{a}\hat{a}^\dagger\hat{\rho} - \hat{\rho}\hat{a}\hat{a}^\dagger] \\ & + \frac{1}{2}(A\rho_{cc}^{(0)} + \kappa(\bar{n}_{th} + 1))[2\hat{b}\hat{\rho}\hat{b}^\dagger - \hat{b}^\dagger\hat{b}\hat{\rho} - \hat{\rho}\hat{b}^\dagger\hat{b}] \\ & + \frac{1}{2}\kappa\bar{n}_{th}[2\hat{b}^\dagger\hat{\rho}\hat{b} - \hat{b}\hat{b}^\dagger\hat{\rho} - \hat{\rho}\hat{b}\hat{b}^\dagger] \\ & + \frac{1}{2}A\rho_{ac}^{(0)}[\hat{a}\hat{b}\hat{\rho} - \hat{a}^\dagger\hat{\rho}\hat{b}^\dagger + \hat{\rho}\hat{a}^\dagger\hat{b}^\dagger - \hat{b}\hat{\rho}\hat{a}] \\ & + \frac{1}{2}A\rho_{ca}^{(0)}[\hat{a}^\dagger\hat{b}^\dagger\hat{\rho} - \hat{a}^\dagger\hat{\rho}\hat{b}^\dagger + \hat{\rho}\hat{a}\hat{b} - \hat{b}\hat{\rho}\hat{a}], \end{aligned} \quad (8)$$

Where,

$$A = \frac{2g^2r_a}{\gamma^2} \quad (9)$$

is linear gain coefficient. The equation of evolution of the density operator associated with the Hamiltonian given by Eq. (2) has the form

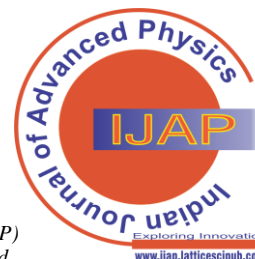

$$\begin{aligned} \frac{d}{dt}\hat{\rho}(t) = & \frac{1}{2}\mu[\hat{\rho}\hat{a}\hat{b} - \hat{a}\hat{b}\hat{\rho} + \hat{a}^\dagger\hat{b}^\dagger\hat{\rho} - \hat{\rho}\hat{a}^\dagger\hat{b}^\dagger] \\ & + \frac{\kappa}{2}(\bar{n}_{th} + 1)[2\hat{a}\hat{\rho}\hat{a}^\dagger - \hat{a}^\dagger\hat{a}\hat{\rho} - \hat{\rho}\hat{a}^\dagger\hat{a}] \\ & + \frac{1}{2}(A\rho_{aa}^{(0)} + \kappa\bar{n}_{th})[2\hat{a}^\dagger\hat{\rho}\hat{a} - \hat{a}\hat{a}^\dagger\hat{\rho} - \hat{\rho}\hat{a}\hat{a}^\dagger] \\ & + \frac{1}{2}(A\rho_{cc}^{(0)} + \kappa(\bar{n}_{th} + 1))[2\hat{b}\hat{\rho}\hat{b}^\dagger - \hat{b}^\dagger\hat{b}\hat{\rho} - \hat{\rho}\hat{b}^\dagger\hat{b}] \\ & + \frac{1}{2}\kappa\bar{n}[2\hat{b}^\dagger\hat{\rho}\hat{b} - \hat{b}\hat{b}^\dagger\hat{\rho} - \hat{\rho}\hat{b}\hat{b}^\dagger] \\ & + \frac{1}{2}A\rho_{ac}^{(0)}[\hat{a}\hat{b}\hat{\rho} - \hat{a}^\dagger\hat{\rho}\hat{b}^\dagger + \hat{\rho}\hat{a}^\dagger\hat{b}^\dagger - \hat{b}\hat{\rho}\hat{a}] \\ & + \frac{1}{2}A\rho_{ca}^{(0)}[\hat{a}^\dagger\hat{b}^\dagger\hat{\rho} - \hat{a}^\dagger\hat{\rho}\hat{b}^\dagger + \hat{\rho}\hat{a}\hat{b} - \hat{b}\hat{\rho}\hat{a}], \end{aligned} \quad (10)$$

This is the master equation for the cavity modes of a non degenerate three-level laser whose cavity contains a non-degenerate para metric amplifier and coupled to a thermal reservoir.

A. The Stochastic Differential equations

Next we seek to determine the solutions of the stochastic differential equations. Thus employing

$$\frac{d}{dt}\langle\hat{A}\rangle = Tr\left(\frac{d}{dt}\hat{\rho}(t)\hat{A}\right), \quad (11)$$

Along with Eq. 11, and applying the cyclic property of the trace operation together with the commutation relations

$$[\hat{a}, \hat{a}^\dagger] = [\hat{b}, \hat{b}^\dagger] = 1 \quad (12)$$

And

$$[\hat{a}, \hat{a}] = [\hat{b}, \hat{b}] = [\hat{a}, \hat{b}] = 0, \quad (13)$$

we readily obtain

$$\frac{d}{dt}\langle\hat{a}\rangle = -\frac{\mu_a}{2}\langle\hat{a}\rangle + \frac{1}{2}\nu_-\langle\hat{b}^\dagger\rangle, \quad (14)$$

$$\frac{d}{dt}\langle\hat{b}\rangle = -\frac{\mu_c}{2}\langle\hat{b}\rangle + \frac{1}{2}\nu_+\langle\hat{a}^\dagger\rangle, \quad (15)$$

$$\frac{d}{dt}\langle\hat{a}^2\rangle = -\mu_a\langle\hat{a}^2\rangle + \nu_-\langle\hat{b}^\dagger\hat{a}\rangle, \quad (16)$$

$$\frac{d}{dt}\langle\hat{b}^2\rangle = -\mu_c\langle\hat{b}^2\rangle + \nu_+\langle\hat{a}^\dagger\hat{b}\rangle, \quad (17)$$

$$\begin{aligned} \frac{d}{dt}\langle\hat{a}^\dagger\hat{a}\rangle = & -\mu_a\langle\hat{a}^\dagger\hat{a}\rangle + \frac{1}{2}\nu_-\langle\hat{a}^\dagger\hat{b}^\dagger\rangle + \frac{1}{2}\nu_+\langle\hat{a}\hat{b}\rangle \\ & + A\rho_{aa}^{(0)} + \kappa\bar{n}, \end{aligned} \quad (18)$$

$$\begin{aligned} \frac{d}{dt}\langle\hat{b}^\dagger\hat{b}\rangle = & -\mu_c\langle\hat{b}^\dagger\hat{b}\rangle + \frac{1}{2}\nu_+\langle\hat{b}^\dagger\hat{a}^\dagger\rangle \\ & + \frac{1}{2}\nu_-\langle\hat{a}\hat{b}\rangle + \kappa\bar{n}, \end{aligned} \quad (19)$$

$$\begin{aligned} \frac{d}{dt}\langle\hat{a}^\dagger\hat{b}\rangle = & -\frac{1}{2}(\mu_a + \mu_c)\langle\hat{a}^\dagger\hat{b}\rangle + \frac{1}{2}\nu_+\langle\hat{a}^\dagger\hat{a}^2\rangle \\ & + \frac{1}{2}\nu_-\langle\hat{b}^\dagger\hat{b}^2\rangle, \end{aligned} \quad (20)$$

$$\begin{aligned} \frac{d}{dt}\langle\hat{a}\hat{b}\rangle = & -\frac{1}{2}(\mu_a + \mu_c)\langle\hat{a}\hat{b}\rangle + \frac{1}{2}\nu_+\langle\hat{a}^\dagger\hat{a}\rangle + \\ & \frac{1}{2}\nu_-\langle\hat{b}^\dagger\hat{b}\rangle + \frac{1}{2}\nu_+, \end{aligned} \quad (21)$$

in which

$$\mu_a = \kappa - A\rho_{aa}^{(0)}, \quad (22)$$

$$\mu_c = \kappa + A\rho_{cc}^{(0)}, \quad (23)$$

$$\nu_\pm = 2\mu \pm A\rho_{ac}^{(0)}. \quad (24)$$

We note that the corresponding c- number are

$$\frac{d}{dt}\langle\alpha\rangle = -\frac{\mu_a}{2}\langle\alpha\rangle + \frac{1}{2}\nu_-\langle\beta^*\rangle, \quad (25)$$

$$\frac{d}{dt}\langle\beta\rangle = -\frac{\mu_c}{2}\langle\beta\rangle + \frac{1}{2}\nu_+\langle\alpha^*\rangle, \quad (26)$$

$$\frac{d}{dt}\langle\alpha^2\rangle = -\mu_a\langle\alpha^2\rangle + \nu_-\langle\beta^*\alpha\rangle, \quad (27)$$

$$\frac{d}{dt}\langle\beta^2\rangle = -\mu_c\langle\beta^2\rangle + \nu_+\langle\alpha^*\beta\rangle, \quad (28)$$

$$\begin{aligned} \frac{d}{dt}\langle\alpha^*\alpha\rangle = & -\mu_a\langle\alpha^*\alpha\rangle + \frac{1}{2}\nu_-\langle\alpha^*\beta^*\rangle + \frac{1}{2}\nu_+\langle\alpha\beta\rangle \\ & + A\rho_{aa}^{(0)} + \kappa\bar{n}, \end{aligned} \quad (29)$$

$$\begin{aligned} \frac{d}{dt}\langle\beta^*\beta\rangle = & -\mu_c\langle\beta^*\beta\rangle + \frac{1}{2}\nu_+\langle\beta^*\alpha^*\rangle + \frac{1}{2}\nu_-\langle\alpha\beta\rangle \\ & + \kappa\bar{n}, \end{aligned} \quad (30)$$

$$\begin{aligned} \frac{d}{dt}\langle\alpha^*\beta\rangle = & -\frac{1}{2}(\mu_a + \mu_c)\langle\alpha^*\beta\rangle + \frac{1}{2}\nu_+\langle\alpha^*\alpha^2\rangle \\ & + \frac{1}{2}\nu_-\langle\beta^*\beta^2\rangle, \end{aligned} \quad (31)$$

$$\begin{aligned} \frac{d}{dt}\langle\alpha\beta\rangle = & -\frac{1}{2}(\mu_a + \mu_c)\langle\alpha\beta\rangle + \frac{1}{2}\nu_+\langle\alpha^*\alpha\rangle \\ & + \frac{1}{2}\nu_-\langle\beta^*\beta\rangle + \frac{1}{2}\nu_+, \end{aligned} \quad (32)$$

On basis of Eqs. [25,26], we can write



$$\frac{d}{dt}\alpha(t) = -\frac{\mu_a}{2}\langle\alpha\rangle + \frac{1}{2}\nu_-\langle\beta^*\rangle + f_\alpha(t), \quad (33)$$

$$\frac{d}{dt}\beta^*(t) = -\frac{\mu_c}{2}\langle\beta\rangle + \frac{1}{2}\nu_+\langle\alpha^*\rangle + f_\beta^*(t), \quad (34)$$

where $f_\alpha(t)$ and $f_\beta(t)$ are noise forces. We now proceed to determine the properties of the noise force. The expectation value of Eqs. (33) and (34) are found to be

$$\frac{d}{dt}\langle\alpha(t)\rangle = -\frac{\mu_a}{2}\langle\alpha\rangle + \frac{1}{2}\nu_-\langle\beta^*\rangle + \langle f_\alpha(t)\rangle, \quad (35)$$

$$\frac{d}{dt}\langle\beta^*(t)\rangle = -\frac{\mu_c}{2}\langle\beta\rangle + \frac{1}{2}\nu_+\langle\alpha^*\rangle + \langle f_\beta(t)\rangle. \quad (36)$$

Comparison of Eqs.(25) and (35) as well as Eqs. (26) and (36) yields

$$\langle f_\alpha(t)\rangle = \langle f_\beta(t)\rangle = 0. \quad (37)$$

The formal solutions of Eqs. 36 and 37 can be put in the form

$$\alpha(t) = \alpha(0)e^{-\frac{\mu_a t}{2}} + \int_0^t e^{-\frac{\mu_a(t-t')}{2}} \left[\frac{1}{2}\nu_-\beta^*(t') + f_\alpha(t') \right] dt', \quad (38)$$

$$\beta^*(t) = \beta(0)e^{-\frac{\mu_c t}{2}} + \int_0^t e^{-\frac{\mu_c(t-t')}{2}} \left[\frac{1}{2}\nu_+\alpha(t') + f_\beta^*(t') \right] dt'. \quad (39)$$

Moreover, applying the relation

$$\frac{d}{dt}\langle\alpha(t)\alpha(t)\rangle = \langle\alpha(t)\left(\frac{d}{dt}\alpha(t)\right)\rangle + \langle\left(\frac{d}{dt}\alpha(t)\right)\alpha(t)\rangle, \quad (40)$$

along with Eq. 35, one can readily verify that

$$\frac{d}{dt}\langle\alpha^2\rangle = -\mu_a\langle\alpha^2(t)\rangle + \nu_-\langle\alpha(t)\rangle + 2\langle\alpha(t)f_\alpha(t)\rangle. \quad (41)$$

With aid of Eq. 36, one can readily verify that using the same relation

$$\langle\beta^*(t)f_\alpha(t)\rangle = 0. \quad (42)$$

In view of this result, one can readily get

$$\int_0^t e^{\frac{\mu_a(t-t')}{2}} \langle f_\alpha(t')f_\alpha(t)\rangle dt' = 0 \quad (43)$$

Applying the relation

$$\int_0^t e^{\frac{1}{2}a(t-t')} \langle f(t)g(t')\rangle dt' = D, \quad (44)$$

we assert that

$$\langle f(t)g(t')\rangle = 2D\delta(t-t'),$$

where a and D are a constants or some function of time t. We then see that

$$\langle f_\alpha(t')f_\alpha(t)\rangle = 0. \quad (45)$$

It can also be established in similar manner that

$$\langle f_\beta(t')f_\beta(t)\rangle = \langle f_\alpha^*(t')f_\beta(t)\rangle = 0. \quad (46)$$

with Eq. 35 and its complex conjugate, we have

$$\frac{d}{dt}\langle\alpha^*\alpha\rangle = -\mu_a\langle\alpha^*\alpha\rangle + \frac{1}{2}\nu_-\langle\alpha^*\beta^*\rangle + \frac{1}{2}\nu_-\langle\alpha\beta\rangle + \langle\alpha^*f_\alpha(t)\rangle + \langle f_\alpha^*(t)\alpha(t)\rangle. \quad (47)$$

III. QUADRATURE VARIANCE

Here we seek to analyse the quadrature squeezing properties of the two-mode light in the cavity can be described by two quadrature's [10]-[16]

$$\hat{c}_+ = \hat{c}^\dagger + \hat{c}, \quad (48)$$

$$\hat{c}_- = i(\hat{c}^\dagger - \hat{c}), \quad (49)$$

Where

$$\hat{c} = \frac{1}{\sqrt{2}}(\hat{a} + \hat{b}), \quad (50)$$

$$\hat{c}^\dagger = \frac{1}{\sqrt{2}}(\hat{a}^\dagger + \hat{b}^\dagger), \quad (51)$$

are the two-mode cavity operators, and \hat{a} and \hat{b} are annihilation operators for cavity modes a and b. In view of Eq.50 and Eq.51, one can write Eq.48) as

$$\hat{c}_+ = \frac{1}{\sqrt{2}}[\hat{a} + \hat{b} + \hat{a}^\dagger + \hat{b}^\dagger]. \quad (52)$$

It then follows that

$$\hat{c}_+ = \frac{1}{\sqrt{2}}[\hat{a}_+ + \hat{b}_+]. \quad (53)$$

Following a similar procedure, we get

$$\hat{c}_- = \frac{i}{\sqrt{2}}[\hat{a}_- + \hat{b}_-], \quad (54)$$

Where,

$$\hat{a}_+ = \hat{a} + \hat{a}^\dagger, \quad \hat{a}_- = i(\hat{a}^\dagger - \hat{a}), \quad (55)$$

$$\hat{b}_+ = \hat{b} + \hat{b}^\dagger, \quad \hat{b}_- = i(\hat{b}^\dagger - \hat{b}). \quad (56)$$

Employing the commutation relation of the cavity mode Operators

$$[\hat{a}, \hat{a}^\dagger] = [\hat{b}, \hat{b}^\dagger] = 1, \quad (57)$$

the quadrature operators \hat{c}_+ and \hat{c}_- are Hermitian and satisfy the commutation relation

$$[\hat{c}_+, \hat{c}_-] = 2i. \quad (58)$$

The variance of the plus and minus quadrature operators of the two-mode cavity light are defined by

$$(\Delta \hat{c}_+)^2 = \langle \hat{c}_+^2 \rangle - \langle \hat{c}_+ \rangle^2 \quad (59)$$

And

$$(\Delta \hat{c}_-)^2 = \langle \hat{c}_-^2 \rangle - \langle \hat{c}_- \rangle^2. \quad (60)$$

On account of Eqs. 48 and 59, the plus quadrature variance can be expressed in terms of the creation and annihilation operators as

$$(\Delta \hat{c}_+)^2 = \langle \hat{c} \hat{c}^\dagger \rangle + \langle \hat{c}^\dagger \hat{c} \rangle + \langle \hat{c}^2 \rangle + \langle \hat{c}^{\dagger 2} \rangle - \langle \hat{c} \rangle^2 - \langle \hat{c}^\dagger \rangle^2 - 2\langle \hat{c} \rangle \langle \hat{c}^\dagger \rangle \quad (61)$$

and with the help of Eqs. (49) and 60, we get

$$(\Delta \hat{c}_-)^2 = \langle \hat{c} \hat{c}^\dagger \rangle + \langle \hat{c}^\dagger \hat{c} \rangle - \langle \hat{c}^2 \rangle - \langle \hat{c}^{\dagger 2} \rangle + \langle \hat{c} \rangle^2 + \langle \hat{c}^\dagger \rangle^2 - 2\langle \hat{c} \rangle \langle \hat{c}^\dagger \rangle, \quad (62)$$

so that inspection of Eqs. 61 and 62) shows that

$$(\Delta \hat{c}_\pm)^2 = \langle \hat{c} \hat{c}^\dagger \rangle + \langle \hat{c}^\dagger \hat{c} \rangle \pm \langle \hat{c}^2 \rangle \pm \langle \hat{c}^{\dagger 2} \rangle \mp \langle \hat{c} \rangle^2 \mp \langle \hat{c}^\dagger \rangle^2 - 2\langle \hat{c} \rangle \langle \hat{c}^\dagger \rangle. \quad (63)$$

This can be expressed in terms of c-number variables associated with the normal ordering as

$$(\Delta \hat{c}_\pm)^2 = \langle \gamma(t) \gamma^*(t) \rangle + \langle \gamma^*(t) \gamma(t) \rangle \pm \langle \gamma^2(t) \rangle \pm \langle \gamma^{*2}(t) \rangle \mp \langle \gamma(t) \rangle^2 \mp \langle \gamma^*(t) \rangle^2 - 2\langle \gamma(t) \rangle \langle \gamma^*(t) \rangle. \quad (64)$$

where $\gamma(t)$ is the c-number variable corresponding to the operator $\hat{c}(t)$. The c-number equation corresponding to Eq. 50 can be written as

$$\dot{\gamma}(t) = \frac{1}{\sqrt{2}} [\alpha(t) + \beta(t)] \quad (65)$$

and application of Eq. 65 to Eq. 64 leads to

$$\Delta c_\pm^2 = 1 \pm \left[\frac{1}{2} [\langle \alpha^2(t) \rangle + \langle \alpha^{*2}(t) \rangle + \langle \beta^2(t) \rangle + \langle \beta^{*2}(t) \rangle] + \langle \alpha(t) \beta(t) \rangle + \langle \alpha^*(t) \beta^*(t) \rangle \pm [\langle \alpha^*(t) \alpha(t) \rangle + \langle \beta^*(t) \beta(t) \rangle + \langle \alpha^*(t) \beta(t) \rangle + \langle \beta^*(t) \alpha(t) \rangle] \right] \mp \frac{1}{2} \langle (\alpha^*(t) + \beta^*(t) \pm \alpha(t) + \beta(t))^2 \rangle. \quad (66)$$

Assuming that the cavity modes are initially in vacuum state along with the fact that a noise force at a certain time does not affect the cavity mode variables at earlier time [17]-[19], we easily find

$$\langle \alpha^2(t) \rangle = 0. \quad (67)$$

In a similar manner, we see that

$$\langle \beta^2(t) \rangle = 0, \quad (68)$$

$$\langle \alpha^*(t) \beta(t) \rangle = \langle \beta^*(t) \alpha(t) \rangle = 0. \quad (69)$$

Now with the aid of Eqs. 67, 68, and 69, we arrive at

$$\Delta c_\pm^2 = 1 + \frac{1}{2} [\langle \alpha(t) \beta(t) \rangle + \langle \alpha^*(t) \beta^*(t) \rangle] \pm \langle \alpha^*(t) \alpha(t) \rangle + \langle \beta^*(t) \beta(t) \rangle. \quad (70)$$

Since $\langle \alpha(t) \beta(t) \rangle = \langle \alpha^*(t) \beta^*(t) \rangle$, we then see that

$$\Delta c_\pm^2 = 1 + \langle \alpha(t) \beta(t) \rangle \pm \langle \alpha^*(t) \alpha(t) \rangle + \langle \beta^*(t) \beta(t) \rangle \quad (71)$$

This takes the form

$$\Delta c_\pm^2 = 1 + \frac{2\kappa A(1-\eta)(2\kappa+2A\eta+A) + 16\mu^2 A\eta - 4\kappa A^2 \eta^2 \bar{n}_{th}}{4[\kappa(\kappa+A\eta) - 4\mu^2](2\kappa+A\eta)} \pm \frac{2\kappa(4\mu + A\sqrt{1-\eta^2})(2\kappa+A\eta+A \pm 4\mu)}{4[\kappa(\kappa+A\eta) - 4\mu^2](2\kappa+A\eta)} + \frac{4\kappa[(2\kappa+A\eta)(2\kappa+A\eta \pm 4\mu)\bar{n}_n + A^2(1 \pm \sqrt{1-\eta^2})\bar{n}_{th}]}{4[\kappa(\kappa+A\eta) - 4\mu^2](2\kappa+A\eta)}. \quad (72)$$

This represents the quadrature variances of the cavity modes for a non-degenerate three level laser whose cavity contains a parametric amplifier and coupled to a thermal reservoir.

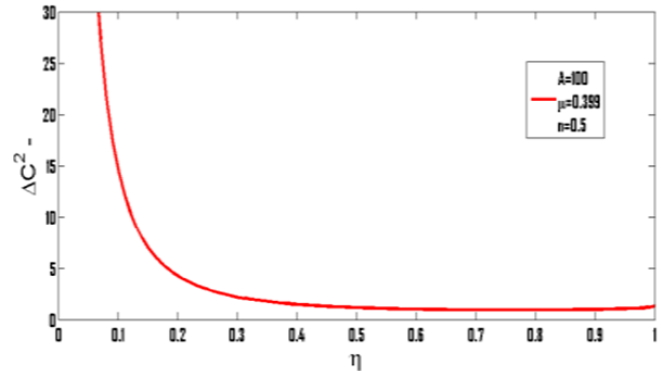

Figure 2. The quadrature variances versus η for $A = 100$, $\kappa = 0.8$, $\mu = 0.399$, and $\bar{n}_{th} = 0.5$

Plot in Fig. 2 indicates that the maximum intracavity Squeezing for the above values and within the parametric amplifier is 50% below the coherent state level. Fig. 2 is the plots of variance of the minus quadrature versus η with parametric amplifier in non-degenerate three-level laser cavity.

Next upon setting $\bar{n}_{th} = \mu = 0$ in Eq. 72, we get

$$\Delta c_\pm^2 = 1 + \frac{A(1-\eta)(2\kappa+2A\eta+A) - A\sqrt{1-\eta^2}(2\kappa+A\eta+A)}{2(\kappa+A\eta)(2\kappa+A\eta)} \quad (73)$$

This is the quadrature variances of the cavity modes for a non-degenerate three-level laser.

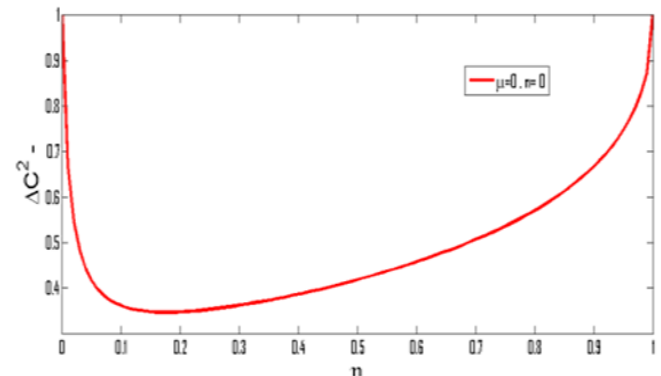

Figure 3. The quadrature variances versus η for $A = 100$, $\kappa = 0.8$, $\mu = 0$, and $\bar{n}_{th} = 0$

In Fig.3 the minimum value of the quadrature variance described by Eq.73 for $A = 100$, $\kappa = 0.8$, and $\bar{n}_{th} = \mu = 0$ is found to be $\Delta c_2 = 0.45$ and occurs at $\eta = 0.16$.

This result implies that the maximum intracavity squeezing for the above values is 40% below the coherent-state level.

The plots in Fig.3 represent the variances of the minus quadrature of the cavity modes for a non- degenerate three-level laser alone.

IV. PHOTON STATISTICS

A. The mean and the variance of the photon number

The mean photon number for the two-modes in terms of density operator can be expressed as

$$\langle \hat{c}^\dagger(t)\hat{c}(t) \rangle = Tr(\rho(t)\hat{c}^\dagger(0)\hat{c}(0)), \quad (74)$$

In which

$$\hat{c} = \hat{a} + \hat{b}, \quad (75)$$

$$\hat{c}^\dagger = \hat{a}^\dagger + \hat{b}^\dagger, \quad (76)$$

where \hat{a} , \hat{b} and \hat{c} are the annihilation operators for a light mode a, light mode b, and the two-mode light, respectively [20]-[24]. Employing Eqs. 73 and 74, Eq. 72 can be written as

$$\langle \hat{c}^\dagger(t)\hat{c}(t) \rangle = \langle \hat{a}^\dagger(t)\hat{a}(t) \rangle + \langle \hat{a}^\dagger(t)\hat{b}(t) \rangle + \langle \hat{b}^\dagger(t)\hat{a}(t) \rangle + \langle \hat{b}^\dagger(t)\hat{b}(t) \rangle. \quad (77)$$

Employing the relation

$$\int d^2\alpha e^{-a\alpha^*\alpha + b\alpha + c\alpha^*} = \frac{\pi}{a} e^{\frac{bc}{a}}, \quad (78)$$

with performing the integration over λ , it yields

$$\langle \hat{a}^\dagger(t)\hat{a}(t) \rangle = \frac{1}{\pi^4} (u^2 - v^2) \frac{d^2}{dx dy} \int d^2\alpha d^2\beta d^2\eta \exp(-\eta^*\eta + \eta^*(\alpha + y) + \eta(\alpha^* + v\beta - v\alpha^*)) \exp(-\alpha^*\alpha + x\alpha + v\alpha^*\beta^* - u\beta^*\beta) |_{x=y=0}, \quad (79)$$

so that carrying out the integration over β and η , there follows

$$\langle \hat{a}^\dagger(t)\hat{a}(t) \rangle = \frac{1}{\pi^4} (u^2 - v^2) \frac{d^2}{dx dy} \int d^2\alpha \exp(-\alpha^*\alpha (\frac{u^2 - v^2}{u} + \alpha^*(uy + -u^2y + v^2y) + x\alpha)) |_{x=y=0}. \quad (80)$$

Performing differentiation, by applying the condition, $x = y = 0$, we readily obtain

$$\langle \hat{a}^\dagger(t)\hat{a}(t) \rangle = a - 1. \quad (81)$$

Similarly, following the same procedure, we note that

$$\langle \hat{b}^\dagger(t)\hat{b}(t) \rangle = b - 1. \quad (82)$$

Now we see that

$$\bar{n} = \frac{2\kappa(4\mu + A\sqrt{1-\eta^2})(2\kappa + A\eta + A - 4\mu)}{4[\kappa(\kappa + A\eta) - 4\mu^2](2\kappa + A\eta)} + \frac{4\kappa[(2\kappa + A\eta)(2\kappa + A\eta + 4\mu)\bar{n}_{th} + A^2(1 - \sqrt{1-\eta^2})\bar{n}_{th}]}{4[\kappa(\kappa + A\eta) - 4\mu^2](2\kappa + A\eta)} \quad (83)$$

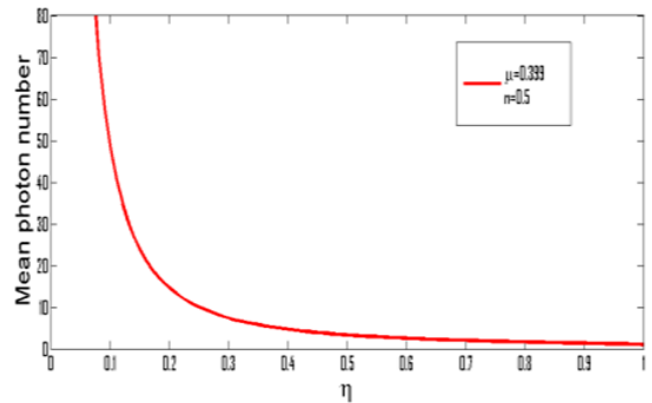

Figure. 4. The mean photon number versus η for $A = 100$, $\kappa = 0:8$, $\mu = 0:399$, and $\bar{n}_{th} = 0:5$

The plot on Fig.4 shows that the mean photon number of Eq. 83 for the values $A = 100$, $\kappa = 0:8$, $\mu = 0:399$, and $\bar{n}_{th} = 0:5$. The results show that as η increases the mean photon number decreases. Finally, in the absence of both parametric amplifier (when $\mu = 0$) and thermal reservoir (when $\bar{n}_{th} = 0$), the mean photon number of Eq.83 turns out to be

$$\bar{n} = \frac{(A\sqrt{1-\eta^2})(2\kappa + A\eta + A)}{2(\kappa + A\eta)(2\kappa + A\eta)}. \quad (84)$$

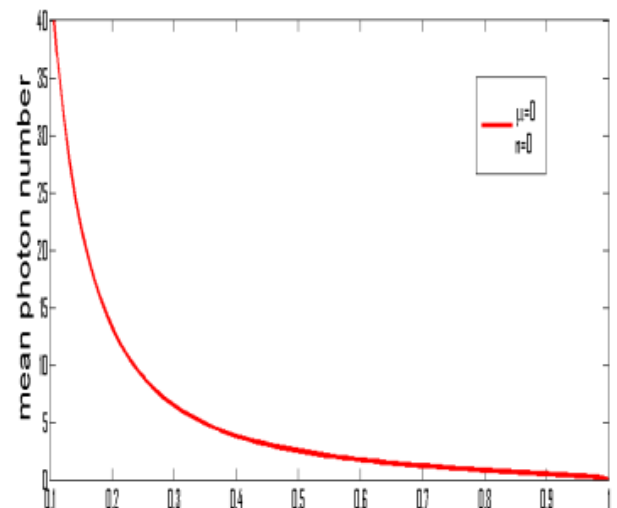

Figure. 5. The mean photon number versus η for $A = 100$, $\kappa = 0:8$, $\mu = 0$, and $\bar{n}_{th} = 0$.

Fig.5 shows that the plot of mean photon number in the absence of both parametric amplifier and thermal reservoir for the values $A = 100$, $\kappa = 0:8$, $\mu = 0$, and $\bar{n}_{th} = 0$. The plot in Fig.5 shows that the mean photon number decrease as η increases.

B. The Variance of the Photon Number Difference

The variance of the photon number at steady state can be expressed as

$$(\Delta n)^2 = \langle (\hat{c}^\dagger\hat{c})^2 \rangle - \langle \hat{c}^\dagger\hat{c} \rangle^2 \quad (85)$$

Where,

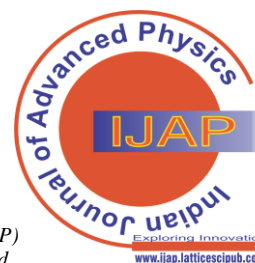

$$\begin{aligned} \hat{c} &= \hat{a} + \hat{b} \\ \hat{c}^\dagger &= \hat{a}^\dagger + \hat{b}^\dagger \end{aligned} \quad (86)$$

And

$$\begin{aligned} \gamma &= \alpha + \beta \\ \gamma^* &= \alpha^* + \beta^* \end{aligned} \quad (87)$$

are c-number variables associated with the normal ordering. The Photon number variance takes the form

$$(\Delta n)^2 = \langle \hat{c}^\dagger \hat{c} \rangle \langle \hat{c} \hat{c}^\dagger \rangle + \langle \hat{c}^2 \rangle \langle \hat{c}^{\dagger 2} \rangle, \quad (88)$$

from which follows

$$(\Delta n)^2 = 2[1 + \langle \hat{c}^\dagger \hat{c} \rangle] + \langle \hat{c}^2 \rangle \langle \hat{c}^{\dagger 2} \rangle. \quad (89)$$

It is possible to write in c-number as

$$\begin{aligned} (\Delta n)^2 &= 2[1 + \langle (\alpha(t) + \beta(t))(\alpha^*(t) + \beta^*(t)) \rangle] + \langle (\alpha(t)\beta(t))^2 \rangle \\ &\quad + \langle (\alpha^*(t) + \beta^*(t)) \rangle \langle (\alpha^*(t) + \beta^*(t)) \rangle. \end{aligned} \quad (90)$$

With the aid of

$$\langle \alpha^*(t)\beta^*(t) \rangle = \langle \alpha(t)\beta(t) \rangle. \quad (91)$$

One can verify that

$$\begin{aligned} (\Delta n)^2 &= 2[1 + \langle \alpha^*(t)\alpha(t) \rangle + \langle \beta^*(t)\beta(t) \rangle] \\ &\quad + 2\langle \alpha(t)\alpha(t) \rangle. \end{aligned} \quad (92)$$

Thus, the variance of the photon number takes the form

$$\begin{aligned} (\Delta n)^2 &= 2 + 2 \left[\frac{2\kappa(4\mu + A\sqrt{1-\eta^2})(2\kappa + A\eta + A - 4\mu)}{4[\kappa(\kappa + A\eta) - 4\mu^2](2\kappa + A\eta)} \right] \\ &\quad + 2 \left[\frac{4\kappa[(2\kappa + A\eta)(2\kappa + A\eta + 4\mu)\bar{n}_{th} + A^2(1 - \sqrt{1-\eta^2})\bar{n}_{th}]}{4[\kappa(\kappa + A\eta) - 4\mu^2](2\kappa + A\eta)} \right] \\ &\quad + 4 \left[\frac{2\kappa A(1-\eta)(2\kappa + 2A\eta + A) + 16\mu^2 A\eta - 4\kappa A^2 \eta^2 \bar{n}}{4[\kappa(\kappa + A\eta) - 4\mu^2](2\kappa + A\eta)} \right]. \end{aligned} \quad (93)$$

This is the photon number variance for a coherently driven three-level laser with parametric amplifier

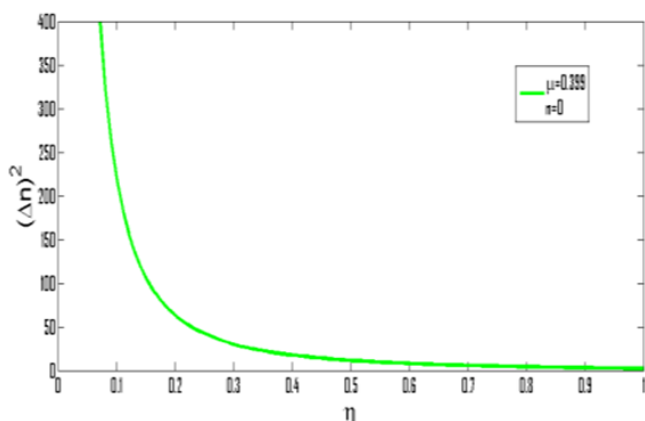

Figure 6. The variance of photon number difference versus η for $A = 100$, $\kappa = 0:8$, $\mu = 0:399$, and $\bar{n}_{th} = 0$

Fig.6 shows that the plot of photon number variance in the absence of thermal reservoir for the values $A = 100$, $\kappa = 0:8$, $\mu = 0:399$, and $\bar{n}_{th} = 0$. The plot in Fig.6 shows that the variance of photon number decrease as η increases. Furthermore, in the absence of both parametric amplifier

(when $\mu = 0$) and thermal reservoir (when $\bar{n}_{th} = 0$, the variance of the photon number described by Eq. 93 reduces to

$$\begin{aligned} (\Delta n)^2 &= 2 + 2 \left[\frac{2\kappa(A\sqrt{1-\eta^2})(2\kappa + A\eta + A)}{4[\kappa(\kappa + A\eta)](2\kappa + A\eta)} \right] \\ &\quad + 4 \left[\frac{2\kappa A(1-\eta)(2\kappa + 2A\eta + A)}{4[\kappa(\kappa + A\eta)](2\kappa + A\eta)} \right]. \end{aligned} \quad (94)$$

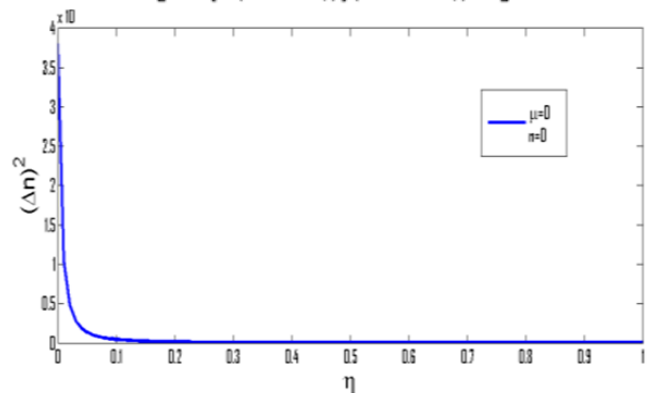

Figure 7. The variance of photon number difference versus η for $A = 100$, $\kappa = 0:8$, $\mu = 0$, and $\bar{n}_{th} = 0$

Fig.7 shows that the plot of photon number variance in the absence of both parametric amplifier and thermal reservoir for the values $A = 100$, $\kappa = 0:8$, $\mu = 0$, and $\bar{n}_{th} = 0$. The plot in Fig.7 shows that the variance of photon number decrease as η increases.

V. ENTANGLEMENT AMPLIFICATION

Here we seek to study the entanglement condition of the two modes in the cavity. A pair of particles is taken to be entangled in quantum theory, if its states cannot be expressed as a product of the states of its individual constituents. The preparation and manipulation of these entangled states that have non-classical and nonlocal properties lead to a better understanding of the basic quantum principles. That is, if the density operator for the combined state cannot be described as a combination of the product of density operators of the constituents,

$$\hat{\rho} \neq \sum_j P_j \hat{\rho}_j^{(1)} \otimes \hat{\rho}_j^{(2)} \quad (95)$$

Where \otimes = bigtimes, $P_j \geq 0$ and $\sum_j P_j = 1$ is set to ensure normalization of the combined density of state.

To study the properties of entanglement produced by this quantum optical system, we need an entanglement criterion for the system. According to the criteria set by Duan et al. [20], a quantum state of the system is entangled provided that the sum of the variances of the two EPR(Einstein-Podolsky-Rosen)-type operators (entanglement) \hat{u} and \hat{v} satisfies the condition;

$$(\Delta \hat{u})^2 + (\Delta \hat{v})^2 < 2, \quad (96)$$

Where,

$$\hat{u} = \hat{x}_a - \hat{x}_b, \hat{v} = \hat{p}_a + \hat{p}_b, \quad (97)$$

With



Entangled Photon Generation From a Three-Level Laser with a Parametric Amplifier and Coupled to a Thermal Reservoir

$$\hat{x}_a = \frac{(\hat{a}^\dagger + \hat{a})}{\sqrt{2}}, \hat{x}_b = \frac{(\hat{b}^\dagger + \hat{b})}{\sqrt{2}}, \quad (98)$$

$$\hat{p}_a = \frac{i(\hat{a}^\dagger - \hat{a})}{\sqrt{2}}, \hat{p}_b = \frac{i(\hat{b}^\dagger - \hat{b})}{\sqrt{2}} \quad (99)$$

being the quadrature operators for modes \hat{a} and \hat{b} . The total variance of the operators \hat{u} and \hat{v} can be written as

$$(\Delta\hat{u})^2 + (\Delta\hat{v})^2 < 2. \quad (100)$$

This implies that

$$(\Delta\hat{u})^2 = \langle u^2 \rangle - \langle u \rangle^2. \quad (101)$$

On account of Eq. 101, we see that

$$(\Delta\hat{u})^2 = \langle (\frac{1}{2}(\hat{a} + \hat{a}^\dagger) - \langle \frac{1}{2}(\hat{a} + \hat{a}^\dagger) \rangle)^2 \rangle, \quad (102)$$

from which follows

$$\begin{aligned} (\Delta\hat{u})^2 &= \frac{1}{2}[1 + 2\langle \hat{a}^\dagger \hat{a} \rangle] - \frac{1}{2}[2\langle \hat{a} \hat{b} \rangle] \\ &\quad - \frac{1}{2}[2\langle \hat{a} \hat{b} \rangle] + \frac{1}{2}[1 + 2\langle \hat{b}^\dagger \hat{b} \rangle]. \end{aligned} \quad (103)$$

It then follows that

$$(\Delta\hat{u})^2 = 1 + 2\langle \hat{a}^\dagger \hat{a} \rangle + 2\langle \hat{b}^\dagger \hat{b} \rangle - 2\langle \hat{a} \hat{b} \rangle. \quad (104)$$

It is possible to write Eq. 104, in case of c-number variables.

$$(\Delta\hat{u})^2 = [1 + 2\langle \alpha^*(t)\alpha(t) \rangle + 2\langle \beta^*(t)\beta(t) \rangle - 2\langle \alpha(t)\beta(t) \rangle]. \quad (105)$$

Following the same procedure, we easily obtain

$$(\Delta\hat{v})^2 = [1 + 2\langle \alpha^*(t)\alpha(t) \rangle + 2\langle \beta^*(t)\beta(t) \rangle - 2\langle \alpha(t)\beta(t) \rangle]. \quad (106)$$

Thus, the sum of the variances of u and v can be expressed as

$$(\Delta\hat{u})^2 + (\Delta\hat{v})^2 = 2(\Delta\hat{u})^2 = 2(\Delta\hat{c}_\pm)^2. \quad (107)$$

We see from this result that the degree of entanglement is directly proportional to the degree of squeezing of the two-mode light. Therefore, we see that

$$(\Delta\hat{u})^2 + (\Delta\hat{v})^2 = 2[1 + 2\langle \alpha^*(t)\alpha(t) \rangle + 2\langle \beta^*(t)\beta(t) \rangle - 2\langle \alpha(t)\beta(t) \rangle]. \quad (108)$$

This can be rewritten as

$$(\Delta\hat{u})^2 + (\Delta\hat{v})^2 = 2 + 2\langle \alpha^*(t)\alpha(t) \rangle + 2\langle \beta^*(t)\beta(t) \rangle - 4\langle \alpha(t)\beta(t) \rangle. \quad (109)$$

In view of Eqs. 73, 74, and 75, Eq. 108 takes the form

$$\begin{aligned} (\Delta\hat{u})^2 + (\Delta\hat{v})^2 &= \\ &= 2 + 2 \left[\frac{2\kappa(4\mu + A\sqrt{1-\eta^2})(2\kappa + A\eta + A - 4\mu)}{4[\kappa(\kappa + A\eta) - 4\mu^2](2\kappa + A\eta)} \right] \\ &+ 2 \left[\frac{4\kappa[(2\kappa + A\eta)(2\kappa + A\eta + 4\mu)(\bar{n}_{th}) + A^2(1 - \sqrt{1-\eta^2})(\bar{n}_{th})]}{4[\kappa(\kappa + A\eta) - 4\mu^2](2\kappa + A\eta)} \right] \\ &+ 4 \left[\frac{2\kappa A(1-\eta)(2\kappa + 2A\eta + A) + 16\mu^2 A\eta - 4\kappa A^2 \eta^2 \bar{n}_{th}}{4[\kappa(\kappa + A\eta) - 4\mu^2](2\kappa + A\eta)} \right]. \end{aligned} \quad (110)$$

We next consider some special cases. We first consider the case in which the parametric amplifier is removed from the cavity. Thus setting $\mu = 0$ in Eq.110, one can readily verify that

$$\begin{aligned} (\Delta\hat{u})^2 + (\Delta\hat{v})^2 &= 2 \left[1 + \frac{A(1-\eta)(2\kappa + 2A\eta) - 2A^2\eta^2\bar{n}_{th}}{2(\kappa + A\eta)(2\kappa + A\eta)} \right. \\ &\quad \left. \pm \frac{A\sqrt{1-\eta^2}(2\kappa + A\eta + A + 2A\bar{n}_{th})}{2(\kappa + A\eta)(2\kappa + A\eta)} \right. \\ &\quad \left. + \frac{[(2\kappa + A\eta)^2\bar{n} + A^2\bar{n}_{th}]}{2(\kappa + A\eta)(2\kappa + A\eta)} \right]. \end{aligned} \quad (111)$$

This represents the photon entanglement of the cavity modes for a non degenerate three level laser coupled to a two-mode squeezed vacuum reservoir.

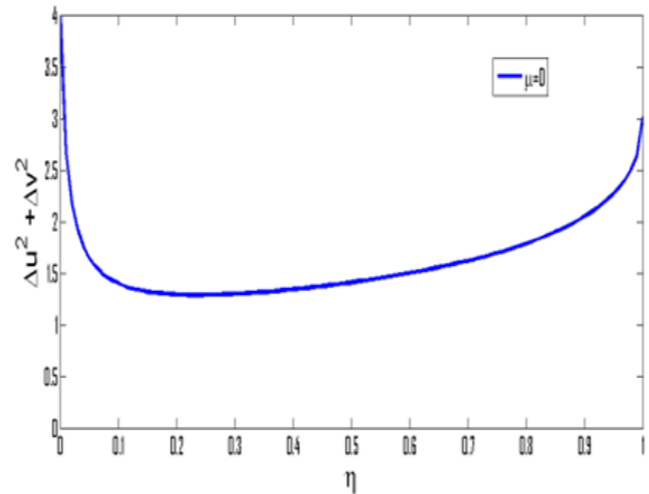

Figure. 8. $\Delta^{\wedge} u^2 + \Delta^{\wedge} v^2$ of two-mode light in the cavity at steady state versus η for $\kappa = 0:8$, $A = 100$, $\mu = 0$, and $\bar{n}_{th} = 0:5$

The minimum value of the photon entanglement is found to be $\Delta^{\wedge} u^2 + \Delta^{\wedge} v^2 = 0:144$ and occurs at $\eta = 0:1$. For $A = 100$, $\kappa = 0:8$, $\mu = 0$, and $\bar{n}_{th} = 0:5$. This indicates that the maximum intra cavity squeezing for the above values and in the absence of parametric amplifier is 90% below the coherent state level. Fig. 8 is the plots of the photon entanglement versus η in the absence of parametric amplifier in non-degenerate three-level laser cavity. This figure shows that the increase of the degree of squeezing due to the parametric amplifier is not significant.

We now consider the case in which the nonlinear crystal is removed from the cavity and the cavity is coupled to a two-mode vacuum reservoir.

Then upon setting $\mu = \bar{n} = 0$ in Eq. 110, we get

$$(\Delta\hat{u})^2 + (\Delta\hat{v})^2 = 2 \left[1 + \frac{A(1-\eta)(2\kappa + 2A\eta + A) - A\sqrt{1-\eta^2}(2\kappa + A\eta + A)}{2(\kappa + A\eta)(2\kappa + A\eta)} \right]. \quad (112)$$

This is the photon entanglement of the cavity modes of a non-degenerate three-level laser with vacuum reservoir.

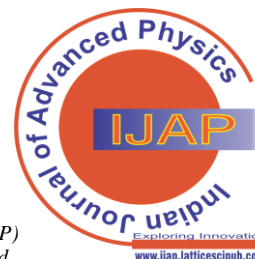

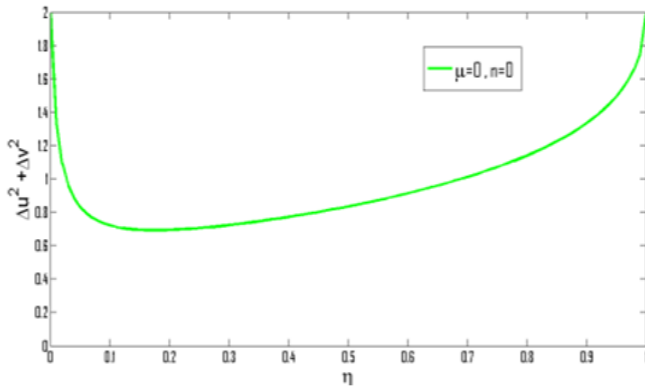

Figure. 9. $\Delta u^2 + \Delta v^2$ of two-mode light in the cavity at steady state versus η for $\kappa = 0.8$, $A = 100$, $\mu = 0$, and $n = 0$

The minimum value of the photon entanglement described by Eq. 112 for $A = 100$, $\kappa = 0.8$, $\mu = 0$ and $n = 0$ is found to be 70% and occurs at $\eta = 0.16$. This result implies that the maximum intracavity squeezing for the above values is 75% below the coherent-state level. The plots in Fig. 9 represent the photon entanglement of the cavity modes for a non-degenerate three-level laser alone. We immediately notice that, this particular entanglement measure is directly related to the two-mode squeezing. This direct relationship shows that whenever there is a two-mode squeezing in the system there will be entanglement in the system as well. It also follows that the degree of entanglement does not depend on the external driving coherent light. This is attributed to the fact that the coherent fields do not introduce additional atomic coherence to the system, as the same is true for the case of squeezing. Using the criterion Eq. 112, that a significant entanglement between the states of the light generated in the cavity of the non-degenerate three-level laser can be manifested due to the strong correlation between the radiations emitted when the atoms decay from the upper energy level to the lower via the intermediate energy level. Based on the criteria Eq. 112, we clearly see from Fig. 9 that the two states of the generated light are strongly entangled at steady state. The entanglement disappears when there is no atomic coherence, and it would be stronger for certain values of the atomic coherence for each value of the linear gain coefficient. It can easily be seen that the degree of entanglement increases with the rate at which the atoms are injected into the cavity, A .

VI. CONCLUSION

In this article we have considered a non-degenerate three-level laser, with the parametric amplifier. First we have derived the master equation in the linear and adiabatic approximations. Then using this master equation, we have obtained stochastic differential equations. Applying the solutions of the resulting differential equations, we have calculated the quadrature variance. In addition, using the same solutions we have determined the mean photon number and mean photon Entanglement. We have also seen that the two-mode driving light has no effect on squeezing of cavity modes. Like the squeezing, the parametric amplifier affects the mean photon numbers and the variance of the photon number difference.

We have also found that increasing the amplitude of the parametric amplifier increases the mean photon numbers and the variances of the photon numbers. We observe that one effect of the squeezed vacuum is to enhance the degree of squeezing of the signal-idler modes. Furthermore, we have seen that the mean photon number of mode a is greater than that of mode b. We have found that both the mean photon number and the quadrature variance for the two-mode laser light beams is the sum of the mean photon numbers and the quadrature variances of the constituent two-mode laser light beams.

ACKNOWLEDGMENT

I would like to thank the anonymous reviewers of the paper for their useful comments.

DECLARATION

Funding/ Grants/ Financial Support	No, I did not receive.
Conflicts of Interest/ Competing Interests	No conflicts of interest to the best of our knowledge.
Ethical Approval and Consent to Participate	No, the article does not require ethical approval and consent to participate with evidence.
Availability of Data and Material/ Data Access Statement	Not relevant.
Authors Contributions	I am only the sole author of the article.

REFERENCES

1. K. Fesseha, "Three-level laser dynamics with squeezed light," *Physical Review A*, vol. 63, no. 3, article 033811, 2001. [CrossRef]
2. J. Anwar and M. S. Zubairy, "Quantum-statistical properties of noise in a phase-sensitive linear amplifier," *Physical Review A*, vol. 49, no. 1, pp. 481–484, 1994. View at: Publisher Site | Google Scholar [CrossRef]
3. N. A. Ansari, "Effect of atomic coherence on the second and higher-order squeezing in a two-photon three-level cascade atomic system," *Physical Review A*, vol. 48, no. 6, pp. 4686–4696, 1993 [CrossRef]
4. B. Daniel and K. Fesseha, "The propagator formulation of the degenerate parametric oscillator," *Optics Communications*, vol. 151, no. 4–6, pp. 384–394, 1998. [CrossRef]
5. B. Teklu, "Parametric oscillation with the cavity mode driven by coherent light and coupled to a squeezed vacuum reservoir," *Optics Communications*, vol. 261, no. 2, pp. 310–321, 2006. [CrossRef]
6. R. Simon, "Peres-horodecki separability criterion for continuous variable systems," *Physical Review Letters*, vol. 84, no. 12, pp. 2726–2729, 2000. [CrossRef]
7. L. M. Duan, G. Giedke, J. I. Cirac, and P. Zoller, "Inseparability criterion for continuous variable systems," *Physical Review Letters*, vol. 84, no. 12, pp. 2722–2725, 2000. [CrossRef]
8. Z. Ficek and P. D. Drummond, "Three-level atom in a broadband squeezed vacuum field. II. Applications," *Physical Review A*, vol. 43, no. 11, pp. 6258–6271, 1991. [CrossRef]
9. M. O. Scully and M. S. Zubairy, *Quantum Optics*, Cambridge University Press, Cambridge, 1997. [CrossRef]
10. C. A. Blockley and D. F. Walls, "Intensity fluctuations in a frequency down-conversion process with three-level atoms," *Physical Review A*, vol. 43, no. 9, pp. 5049–5056, 1991 [CrossRef]



Entangled Photon Generation From a Three-Level Laser with a Parametric Amplifier and Coupled to a Thermal Reservoir

11. S. M. Barnett and M. Radmore, *Methods in Theoretical Quantum Optics*, (Clarendon Press, Oxford, 1997).
12. N. Lu, F. X. Zhao, and J. Bergou, "Nonlinear theory of a two photon correlated-spontaneous-emission laser: a coherently pumped two-level-two-photon laser," *Physical Review A*, vol. 39, no. 10, pp. 5189–5208, 1989 [[CrossRef](#)]
13. K. Fesseha, "Three-level laser dynamics with the atoms pumped by electron bombardment," 2012, <https://arxiv.org/abs/1105.1438>.
14. K. Dechoum, P. D. Drummond, S. Chaturvedi, and M.D.Reid, *Phys. Rev. A* 70,053807 (2004). [[CrossRef](#)]
15. Y. Zhang, H. Wang, X. Li, J. Jing, C. Xie, and K. Peng, *Phys.Rev. A* 62, 023813(2000). [[CrossRef](#)]
16. H. Xiong, M. O. Scully, and M. S. Zubairy, "Correlated spontaneous emission laser as an entanglement amplifier," *Physical Review Letters*, vol. 94, no. 2, article 023601, 2005. [[CrossRef](#)]
17. T. Y. Darge and F. Kassahun, "Coherently driven degenerate three-level laser with parametric amplifier," *PMC Physics B*, vol.3, p. 1, 2010. [[CrossRef](#)]
18. H. Jeong, J. Lee, and M. S. Kim, "Dynamics of nonlocality for a two-mode squeezed state in a thermal environment," *Physical Review A*, vol. 61, no. 5, article 052101, 2000. [[CrossRef](#)]
19. S. Tesfa, "Entanglement amplification in a nondegenerate three-level cascade laser," *Physical Review A*, vol. 74, no. 4, article 43816, 2006. [[CrossRef](#)]
20. J M Liu, B S Shi, X F Fan, J Li and G C Guo. Wigner function description of continuous variable entanglement swapping. *J. Opt. B: Quant. Semiclass. Opt.* 3, 189 (2001). [[CrossRef](#)]
21. S L Braunstein and H J Kimble. Dense coding for continuous variables. *Phys. Rev. A* 61, 42302 (2000). [[CrossRef](#)]
22. S Lloyd and S L Braunstein. Quantum Computation over Continuous Variables. *Phys. Rev. Lett.* 82, 1784 (1999). [[CrossRef](#)]
23. S L Braunstein. Quantum error correction for communication with linear optics. *Nature* 394, 47 (1998). [[CrossRef](#)]
24. T C Ralph. Continuous variable quantum cryptography. *Phys.Rev.A* 61,010302 (2000). [[CrossRef](#)]
25. Solomon Getahun, *Fundamental Journal Modern Physics*, Vol. 8, issue 1,(2015)
26. F. Kassahun, *Refind Quantum Analysis of Light*, Create Space Independent Publishing Platform, USA, 2014.
27. M. O. Scully and M. S. Zubairy, "Noise free amplification via the two-photon correlated spontaneous emission laser," *Optics Communication*, vol. 66, pp. 303–306, 1988. [[CrossRef](#)]

AUTHORS PROFILE

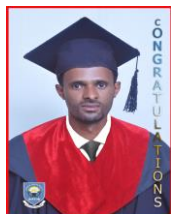

Negasa Belay, I have B.Ed. Degree in Bachelor of Science in Physics and M.Sc. in Physics (Quantum Optics and Information).

Publications

1. T. Abebe, S. Mosissa, and **N. Belay**, "Coherently driven two-level atom in open space and interacting with vacuum modes," *Bulgarian Journal of Physics*, vol. 46, no. 3, pp. 214–228, 2019. View at: [Google Scholar](#)

2. Belay, N. (2023). Two-Mode Sub harmonic Generator Coupled to Thermal Reservoir. *Universal Journal of Physics Research*, 2(1), 19–37. Retrieved from

<https://www.scipublications.com/journal/index.php/ujpr/article/view/564>

Disclaimer/Publisher's Note: The statements, opinions and data contained in all publications are solely those of the individual author(s) and contributor(s) and not of the Lattice Science Publication (LSP)/ journal and/ or the editor(s). The Lattice Science Publication (LSP)/ journal and/or the editor(s) disclaim responsibility for any injury to people or property resulting from any ideas, methods, instructions or products referred to in the content.